

Accu-Device Kombi 7011-DS3

For operation on
EC construction sites only
permissible with mechanical
holding device according to
EN 13155

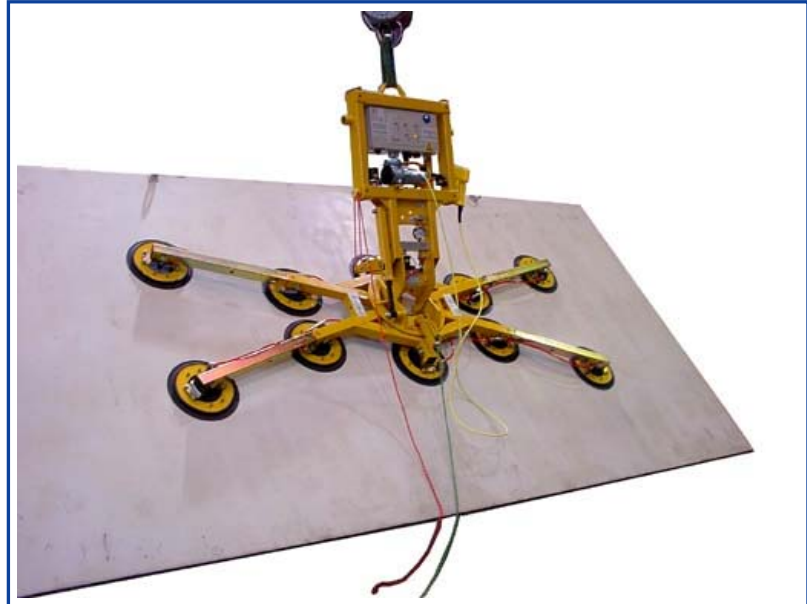

Description

- **1-circuit vacuum system**
- the vacuum circuit has a vacuum tank with nonreturn valve, vacuum switch and control vacuum meter
- **completely closed vacuum circuit**
prevents loss of vacuum at power failure
- warning lamp and acoustic signal indicate insufficient vacuum
- extendable to 14 suction cups with extensions
- all suction cups lockable individually
- turning device with roller bearings and locking every 90°
- tilting device (0° to 90°) with locking device every 3°
- **maximum structural depth 230 mm**
- extendable at maximum by 6 extensions

Vacuum Generation

- built-in low maintenance rechargeable battery vacuum pump (dry running system)
- for rechargeable battery and line operation without change-over
- built-in accumulator charger for charging over night
- no cable - no hose

Operation

- ON/OFF directly at the device
- SUCTION/RELEASE via hand valve at the device
- optional via remote control
- turning tackle
- tilting tackle

Suspension: crane eye at the carrying frame
Load capacity : 600 kg / 1200 kg
Colour: yellow / partly zinked

	vertical
	horizontal
	turning through +/- 360 degrees
	tilting through 90 degrees

suitable for lifting				
material properties	gas-tight			
surface	smooth			
e. g.	glass panes, sealed units, window and curtain walling elements, plastic and ceramic plates, coated boards			
suction cup type	388			
diameter in action approx. mm	300			
quality of suction cups	black rubber abrasion possible up to 80° C heat resistant from 4 mm glass thickness			
number of suction cups	6	8	10	12
number of extension pieces:	0	2	4	6
safe working load on smooth and clean surface at 60 % vacuum on construction sites outside the EU / in-company kg	600	700	900	1000
outer distance of the suction cup approx. mm	1350 x 620	1350 x 1850	2550 x 990	2550 x 1850
dead weight approx. kg				
distribution voltage charger for battery	230 V / 50/60 Hz / 1 phase			
Item No.: 7011-DS3...	-6&0	-6&2	-6&4	-6&6
distribution voltage charger for battery	110 V / 50/60 Hz / 1 phase			
Item No.: 7011-DS3-110...	-6&0	-6&2	-6&4	-6&6
number of suction cups	8	10	12	14
number of extension pieces:	0	2	4	6
safe working load on smooth and clean surface at 60 % vacuum on construction sites outside the EU / in-company kg	800	900	1000	1200
outer distance of the suction cup approx. mm	1350 x 620	1350 x 1850	2550 x 990	2550 x 1850
dead weight approx. kg				
distribution voltage charger for battery	230 V / 50/60 Hz / 1 phase			
Item No.: 7011-DS3...	-8&0	-8&2	-8&4	-8&6
distribution voltage charger for battery	110 V / 50/60 Hz / 1 phase			
Item No.: 7011-DS3-110...	-8&0	-8&2	-8&4	-8&6

Accessories on request	
Item No.: 388-SCHUTZ	protection cap for suction cup 388
Item No.: 7003-GTGDS3	transport carriage for Kombi 7011-DS3 / 7211-DS3
Item No.: 7003-WSP	rain cover for transport carriage including Kombi DS3
Item No.: 7003-KB-2K	cable remote control SUCTION / RELEASE
Item No.: 7003-IFB-2K	infrared remote control SUCTION / RELEASE



Kombi 7011-DS3
possible suction cup arrangement on the base frame

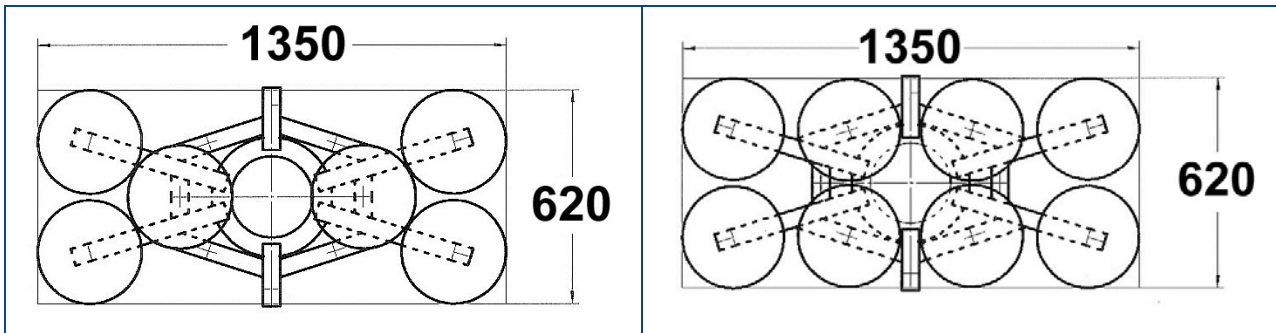

Kombi 7011-DS3 with 2 extensions
each extension with one suction cup 388

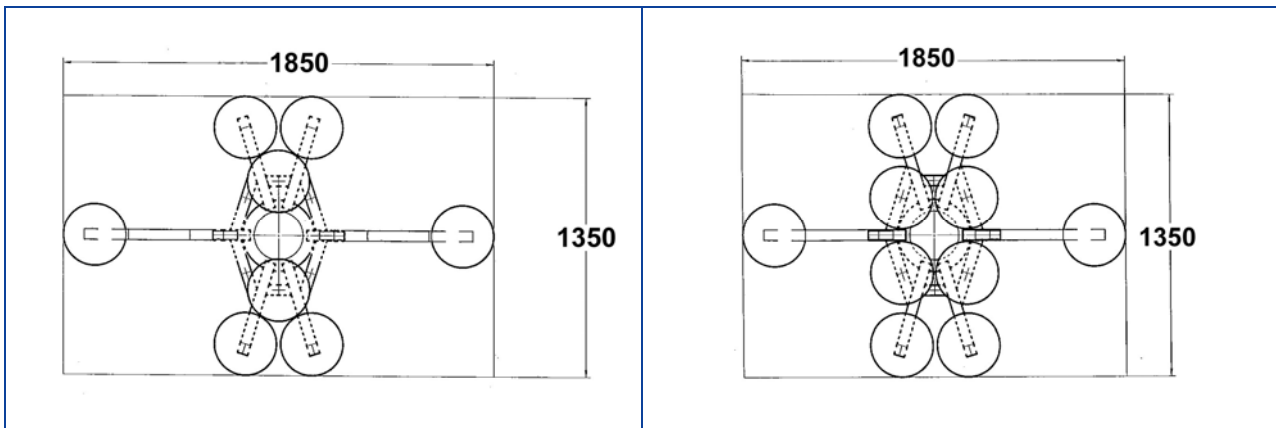

Kombi 7011-DS3 with 4 extensions
each extension with one suction cup 388

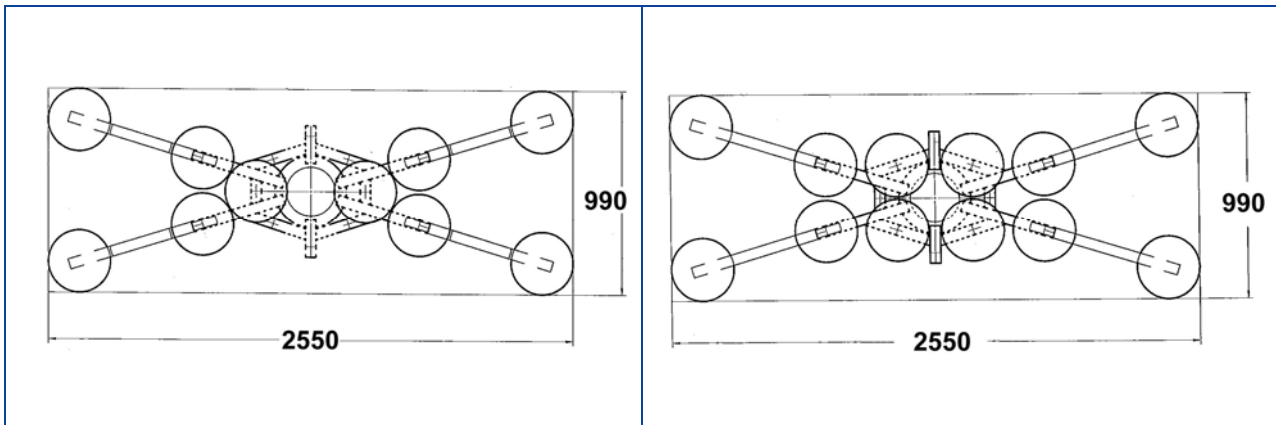

Kombi 7011-DS3 with 6 extensions
each extension with one suction cup 388

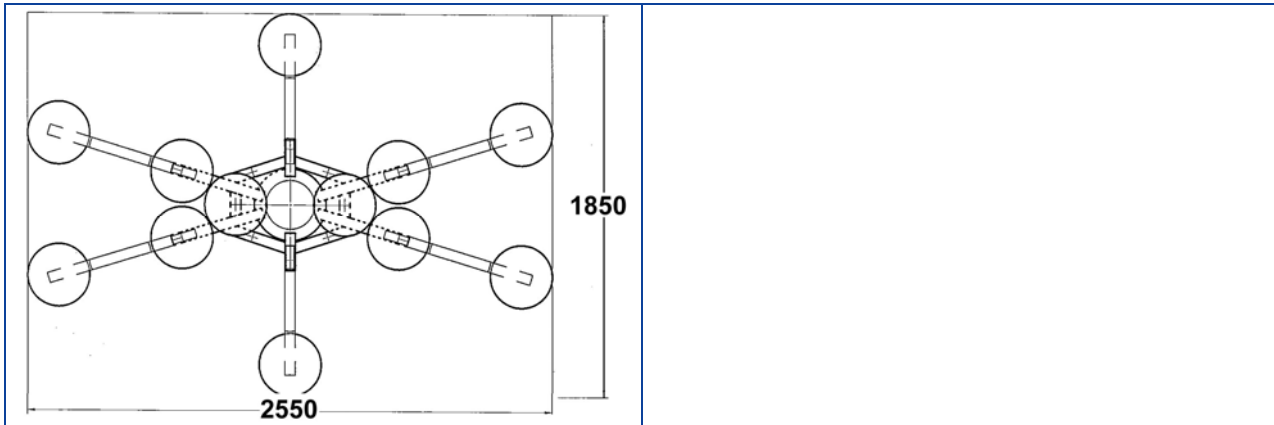

Kombi 7011-DS3 with 4/6 extensions
each extension with two suction cups 388

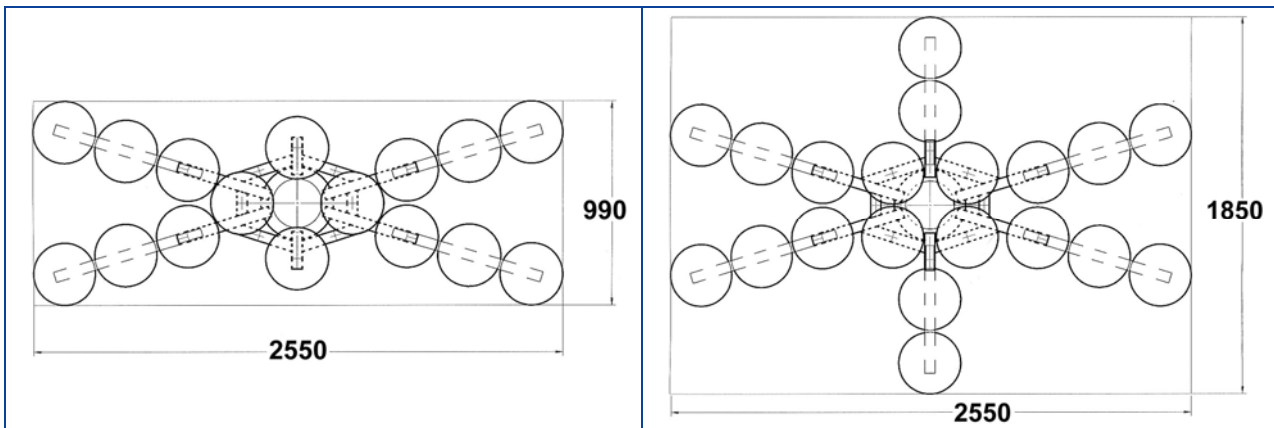

Kombi 7011-DS3
special option of the suction cup arrangement

